

# TriOxmatic® 702 IQ

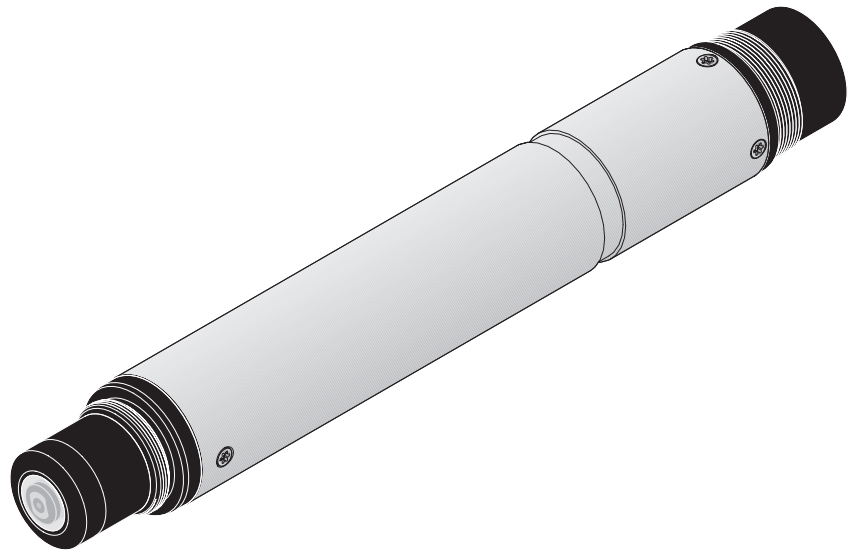

**IQ SENSOR NET D.O. sensor**



## TriOxmatic® 702 IQ - Contents

<b>1</b>	<b>Overview</b>	<b>2-1</b>
1.1	How to use this component operating manual	2-1
1.2	Structure of the TriOxmatic® 702 IQ D.O. sensor	2-2
1.3	Recommended fields of application	2-2
<b>2</b>	<b>Safety</b>	<b>3-1</b>
2.1	Authorized use	3-2
2.2	General safety instructions	3-2
<b>3</b>	<b>Commissioning</b>	<b>4-1</b>
3.1	Scope of delivery	4-1
3.2	Installation	4-1
3.3	Commissioning / Getting the instrument ready for measuring	4-3
3.4	TriOxmatic® 702 IQ setting table	4-4
<b>4</b>	<b>Measuring / Operation</b>	<b>5-1</b>
4.1	Measuring	5-1
4.2	Calibration	5-1
4.2.1	General information on calibration	5-1
4.2.2	Calibration in water vapor-saturated air	5-2
4.2.3	Calibration history (software version 2.21 or higher)	5-4
4.2.4	Reactivation of the last valid calibration (software version 2.21 or higher)	5-4
4.3	Function check	5-5
<b>5</b>	<b>Maintenance, cleaning, disposal, and replacement</b>	<b>6-1</b>
5.1	General maintenance instructions	6-1
5.2	Cleaning the sensor shaft and membrane	6-2
5.3	Changing the electrolyte and membrane cap	6-3
5.4	Cleaning the electrodes	6-7
5.4.1	Cleaning the gold working electrode	6-9
5.4.2	Cleaning the silver counter electrode	6-10
5.5	Check the sensor for freedom from zero current	6-15
5.6	Storage	6-16
5.7	Disposal	6-16
5.8	Maintenance equipment and replacement parts	6-17

---

<b>6</b>	<b>What to do if...</b>	<b>7-1</b>
<b>7</b>	<b>Technical data</b>	<b>8-1</b>
7.1	Measurement characteristics	8-1
7.2	Application characteristics	8-2
7.3	General data	8-3
7.4	Electrical data	8-3
7.5	Characteristic data on delivery	8-4
<b>8</b>	<b>Indexes</b>	<b>9-1</b>
8.1	Explanation of the messages	9-1
8.1.1	Error messages	9-1
8.1.2	Info messages	9-2
8.2	Status info	9-3

# 1 Overview

## 1.1 How to use this component operating manual

### Structure of the IQ SENSOR NET operating manual

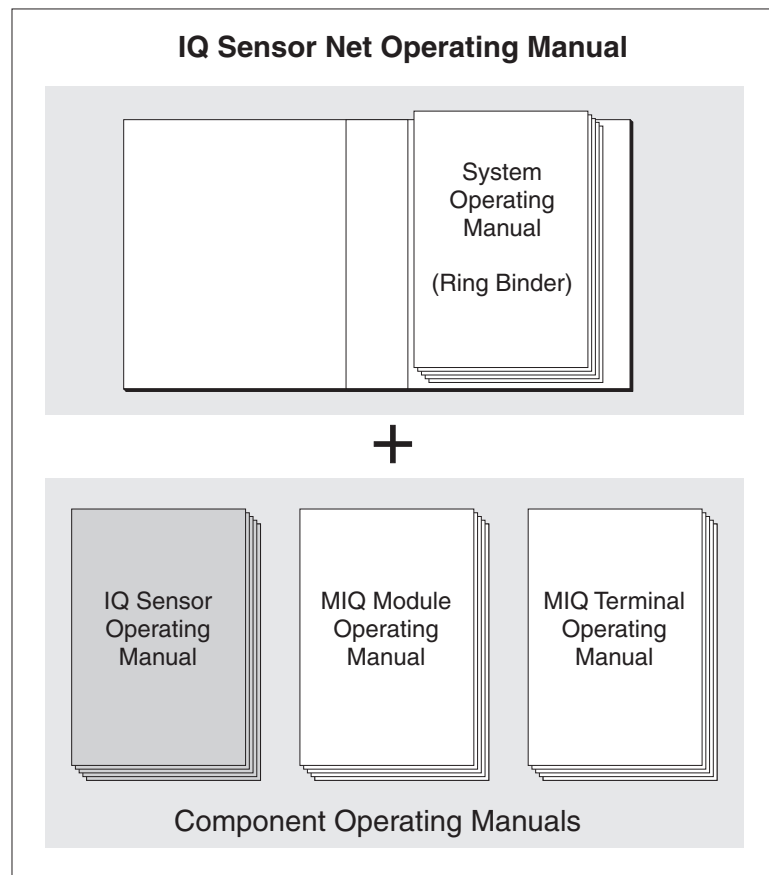

Fig. 1-1 Structure of the IQ SENSOR NET operating manual

The IQ SENSOR NET operating manual has a modular structure like the IQ SENSOR NET system itself. It consists of a system operating manual and the operating manuals of all the components used.

Please file this component operating manual into the ring binder of the system operating manual.

### 1.2 Structure of the TriOxmatic® 702 IQ D.O. sensor

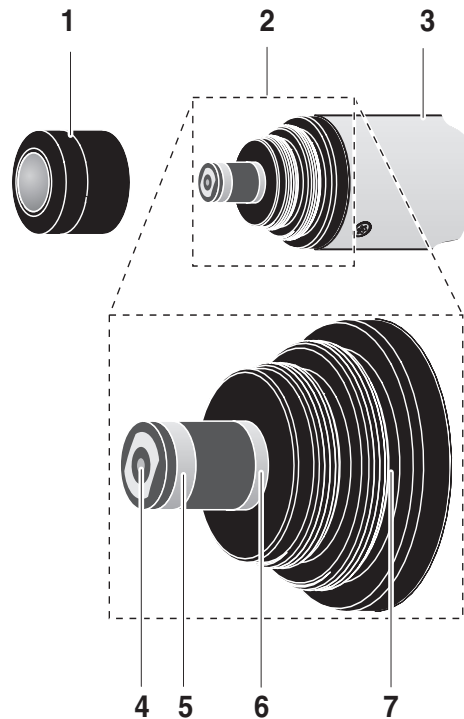

Fig. 1-2 Structure of the TriOxmatic® 702 IQ D.O. sensor

1	WP 25i membrane head
2	Electrode unit
3	Shaft
<b>Electrode unit:</b>	
4	Gold working electrode (cathode)
5	Silver counter electrode (anode)
6	Reference electrode

### 1.3 Recommended fields of application

Stationary measurements in boiler feed water and trace measurements in water. The measurement is a flow-thru measurement, e.g. uses the D702/N flow-thru vessel (available as an accessory).

## 2 Safety

This component operating manual contains special instructions that must be followed during the operation of the TriOxmatic® 702 IQ D.O. sensor. Thus, it is essential to read this component operating manual before carrying out any work using this sensor. In addition to this manual, the SAFETY chapter of the IQ SENSOR NET system operating manual must be followed.

Always keep this component operating manual together with the system operating manual and any other component operating manuals in the vicinity of the IQ SENSOR NET system.

### Special user qualifications

The D.O. sensor was developed for applications using the online measurement technique. Thus, we assume that the operators are familiar with the necessary precautions to take when dealing with chemicals as a result of their professional training and experience.

### General safety instructions

Safety instructions in this operating manual can be recognized by the warning symbol (triangle) in the left column. The signal word (e. g. "Caution") indicates the level of the danger:



#### Warning

indicates instructions that must be followed precisely in order to prevent serious dangers to persons.



#### Caution

indicates instructions that must be followed precisely in order to avoid slight injuries or damage to the instrument or the environment.

### Other labels



#### Note

indicates notes that draw your attention to special features.

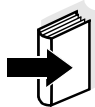

#### Note

indicates cross-references to other documents, e.g. operating manuals.

## 2.1 Authorized use

The authorized use of the TriOxmatic® 702 IQ comprises its use as a D.O. sensor in the IQ SENSOR NET.

The technical specifications according to chapter 7 TECHNICAL DATA must be observed. Only operation according to the instructions in this operating manual is authorized.

Any other use is considered to be **unauthorized**. Unauthorized use invalidates any claims with regard to the guarantee.



### Caution

**Only connect and operate the sensor together with IQ SENSOR NET accessories.**

## Function and operational safety

## 2.2 General safety instructions

The sensor left the factory in a safe and secure technical condition.

The failure-free function and operational safety of the sensor is only guaranteed if the generally applicable safety measures and the special safety instructions in this operating manual are followed during its use.

The failure-free function and operational safety of the sensor is only guaranteed under the environmental conditions that are specified in chapter 7 TECHNICAL DATA.

The specified temperature (chapter 7 TECHNICAL DATA) must be maintained during the operation and transport of the sensor. Protect the sensor, particularly against frost or overheating.



### Caution

**The sensor may only be opened by specialists authorized by WTW. The only exceptions to this are the activities described in chapter 5 MAINTENANCE, CLEANING, DISPOSAL, AND REPLACEMENT.**



**Safe operation**

If safe operation is no longer possible, the sensor must be taken out of operation and secured against inadvertent operation.

Safe operation is no longer possible if the sensor:

- has been damaged in transport
- has been stored under adverse conditions for a lengthy period of time
- is visibly damaged
- no longer operates as described in this manual.

If you are in any doubt, contact the supplier of your sensor.

**Obligations of the operator**

The operator of the sensor must ensure that the following rules and regulations are followed when dealing with hazardous substances:

- EEC directives for protective labor legislation
- National protective labor legislation
- Safety regulations
- Safety data sheets of the chemical manufacturer.



## 3 Commissioning

### 3.1 Scope of delivery

- TriOxmatic® 702 IQ
- ZBK 25i accessory case
- RA 600 cleaning attachment
- The sensor is filled with electrolyte and provided with a protective hood.
- Operating manual.

### 3.2 Installation

#### Connection cable

The SACIQ sensor connection cable is required to connect the sensor. Information on this and other IQ SENSOR NET accessories is given in the WTW catalog and on the Internet.



#### Are the plug connections dry?

##### Note

How to connect the SACIQ sensor connection cable to the terminal strip of an MIQ module is described in chapter 3 INSTALLATION of the IQ SENSOR NET system operating manual.

Before connecting the sensor and sensor connection cable, please make sure the plug connections are dry. If moisture gets into the plug connections, first dry the plug connections (dab them dry or blow them dry using compressed air).



##### Note

Do not suspend the sensor on the sensor connection cable. Use an armature or flow-thru vessel. We recommend to perform the measurement and installation in the D 702/N flow-thru vessel using the ADA-DF 4 and ADA-DF 6 adapters.

Information on this and on other IQ SENSOR NET accessories is given in the WTW catalog and on the Internet.

#### Minimum approach flow

The minimum required approach flow at the sensor must be present during measurement (see chapter 7 TECHNICAL DATA). The minimum approach flow can, e.g. be achieved by:

- the flow rate of the water
- the correct flow-thru in the flow-thru vessel.

**Connecting the sensor  
to the sensor  
connection cable**

- |   |   |
|---|---|
| 1 | Take the protective caps off the plug connections of the sensor and the SACIQ sensor connection cable and keep them safe.   |
| 2 | Plug the jack of the SACIQ sensor connection cable onto the plug head connector of the sensor. At the same time, rotate the socket so that the pin in the plug head connector (1) clicks into one of the two holes in the jack. |
| 3 | Then, screw the coupling ring (2) of the sensor connection cable onto the sensor up to the stop.  |

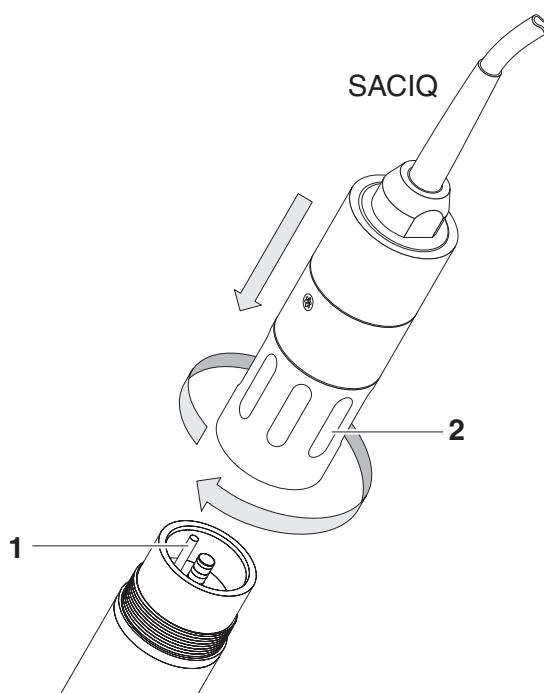

Fig. 3-1 Connecting the sensor

### 3.3 Commissioning / Getting the instrument ready for measuring

1	Pull the protective cap off the sensor.
2	Leave the sensor to lie in the air for at least 60 minutes while it is switched on (polarization).



#### Note

For the sensor to polarize, the following conditions must be fulfilled:

- The sensor is connected with the IQ SENSOR NET system via the SACIQ sensor connection cable.
- The IQ SENSOR NET system is in operation
- The sensor has been identified by the IQ SENSOR NET system.

3	If required, assign a user-defined name to the sensor (see relevant IQ SENSOR NET system operating manual).
4	Set the sensor (see section 3.4).
5	Calibrate the sensor (see section 4.2 CALIBRATION).

#### Precision measurements

Recommendation: In order to carry out precision measurements, leave the sensor to polarize for a longer period of time, e.g. overnight, and recalibrate it the following day.

### 3.4 TriOxmatic® 702 IQ setting table

Setting	Selection/values	Explanation
<i>Measuring mode</i>	<ul style="list-style-type: none"> <li>● <i>Concentration</i></li> <li>● <i>Saturation</i></li> </ul>	Unit of the measured value on the measured value display.
<i>Measuring range Concentration</i>	<ul style="list-style-type: none"> <li>● <i>0 ... 2000 µg/l</i></li> <li>● <i>0.0 ... 15 mg/l</i></li> <li>● <i>0 ... 2000 ppb</i></li> <li>● <i>0 ... 10.00 ppm</i></li> </ul>	These measuring ranges are available for selection.
<i>Measuring range Saturation</i>	<ul style="list-style-type: none"> <li>● <i>0 ... 110.0 %</i></li> </ul>	The measuring range is set permanently.
<i>Calibration</i> (software version 2.21 or higher)	<ul style="list-style-type: none"> <li>● <i>valid</i></li> <li>● <i>invalid</i></li> <li>● <i>last valid</i></li> <li>● <i>active</i></li> <li>● <i>abort</i></li> </ul>	<p>Displays and determines which calibration data the measured value calculation is based on. The active calibration is displayed in the calibration history (see section 4.2.3).</p> <p><i>valid</i> indicates that a valid calibration is available. The value cannot be changed.</p> <p><i>invalid</i> is displayed if the last calibration is invalid and the sensor is blocked for measurement. In this case, you can switch to the values of the <i>last valid</i> calibration, provided a valid calibration is available in the sensor. Thus you activate the last valid calibration stored in the sensor the next time you exit the setting table with <i>Save and quit</i>. The next time the setting table is opened, <i>valid</i> is displayed.</p> <p><i>active</i> indicates that the sensor is being calibrated. If <i>Cancel</i> is selected, the active calibration procedure is canceled as soon as the setting table is exited with <i>Save and quit</i>.</p>
<i>Temperature mode</i>	<ul style="list-style-type: none"> <li>● °C</li> <li>● °F</li> </ul>	Unit of the measured temperature value (Celsius, Fahrenheit).

<i>Temp. adjustment</i>	-1.5 K ... +1.5 K	<p>The temperature compensation enables the tolerances of the temperature sensor to be balanced (shifting of the zero point by <math>\pm 1.5</math> K).</p> <p>Notes:</p> <ul style="list-style-type: none"> <li>● Due to the thermal capacity of the sensor, it is necessary to place it in a container with at least 2 liters of water.</li> <li>● Leave the sensor in this container for at least 15 minutes while stirring occasionally until the balancing can be performed.</li> </ul> <p>With temperature differences between the water and sensor <math>&gt; 10</math> °C, leave the sensor for at least 1 hour in this container while stirring occasionally until the balancing can be performed.</p>
<i>Save and quit</i>		The system confirms the saving of the settings and the display switches to the next higher level.
<i>Quit</i>		The display switches to the next higher level without saving the new settings.

### Carrying out settings

Using , switch from the measured value display to the main menu of the settings. Then navigate to the setting menu (setting table) of the sensor. The exact procedure is given in the relevant IQ SENSOR NET system operating manual.





## 4 Measuring / Operation

### 4.1 Measuring

1	Install the sensor in the D 702/N flow-thru vessel (see operating manual of the flow-thru vessel) and put it into operation with the measuring medium.
2	Read the measured value on the terminal of the IQ SENSOR NET system.

### 4.2 Calibration

#### 4.2.1 General information on calibration

<b>Why calibrate?</b>	During the operation of a D.O. sensor, the slope of the D.O. sensor changes with time. The calibration procedure determines the current slope of the sensor.
<b>When to calibrate?</b>	Calibrate before measuring and at regular intervals (depending on the application).
<b>Calibration procedures</b>	Ideally, calibration takes place in water vapor-saturated air. To do so, position the sensor approx. 2 cm above a water surface, for example in a narrow bucket or similar container with water. In the case of air temperatures under 5 °C we recommend to calibrate not in air but in air-saturated water that has a higher temperature. You obtain air-saturated water by pouring water several times in and out of two vessels so that it sparkles.
<b>Calibration log</b>	The calibration history contains the calibration log of the current and the last calibration. You can call up the calibration reports for the sensor via the <i>Calibration history</i> display option.
	<b>Note</b> For calibration the membrane always has to be clean, for calibration in air it has to be dry. Clean contaminated sensors before calibration (see section 5.2 CLEANING THE SENSOR SHAFT AND MEMBRANE).
<b>Maintenance condition</b>	During calibration the sensor is in the so-called maintenance condition. This means all linked outputs retain their momentary state. After finishing calibration the maintenance condition has to be switched off manually. For more detailed information on the maintenance condition please refer to the respective IQ SENSOR NET system operating manual.

### General course of a calibration on the IQ SENSOR NET

Generally, calibration on the IQ SENSOR NET is carried out as follows. System specific details are given in the respective IQ SENSOR NET system operating manual.

1	Switch to the measured value display with <b>(M)</b> and select the sensor to be calibrated.
2	Call up calibration with <b>(C)</b> . The next step switches on the maintenance condition for the sensor. A corresponding note appears on the display.
3	Confirm the note with <b>(OK)</b> . The maintenance condition is active. The menu-guided calibration routine starts. Follow the instructions on the display. After the calibration routine is finished, the measured value display appears again (the measured value flashes because the sensor is still in the maintenance condition).
4	If the calibration was successful, bring the sensor into the measuring position.
5	Wait for a stable measured value.
6	Switch off the maintenance condition.

#### 4.2.2 Calibration in water vapor-saturated air

1	If necessary, clean the sensor and membrane and dry the membrane (see section 5.2 CLEANING THE SENSOR SHAFT AND MEMBRANE).
2	Start calibration and follow the instruction on the display until the instruction <i>Bring sensor into calibrating position</i> appears.

#### Calibrating position

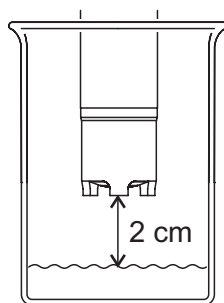

- 3 Bring the sensor into the calibrating position.  
To do so, position the sensor approx. 2 cm above a water surface, best in a narrow bucket or similar container with water. When doing so, no liquid should be brought on the membrane.



**Note**

Up to this point, you can break off the calibration procedure at any time with the **ESC** key. The system continues to work with the old calibration data. However, you have to switch off the maintenance condition in any case.

After starting the calibration with the **OK** key (step 4), you cannot break off the calibration any more.

- 4 Continue with **OK**.  
The calibration data is automatically determined and documented in the calibration record.

- 5 Complete the calibration procedure according to the instructions on the display.



**Note**

In the case of air temperatures under 5 °C do not calibrate the sensor in air but in air-saturated water that has a higher temperature. You obtain air-saturated water by pouring water several times in and out of two vessels so that it sparkles. Then immerse the sensor in a vessel with air-saturated water and calibrate as described above.

**Possible results of the calibration**

The calibration data are evaluated by the system. A calibration can have the following results:

Display after the calibration	Log book entries (meaning/actions)
Measured value display	Sensor was successfully calibrated. For the calibration data, see the calibration history.
"----"	Sensor could not be calibrated. Sensor blocked for measurement. – Service the sensor immediately (see operating manual). – View calibration history. – Check calibration conditions and calibration standard.

### 4.2.3 Calibration history (software version 2.21 or higher)

**Calibration history  
(available in the  
IQ SENSOR NET systems  
184 XT and 2020 XT  
only)**

HIQ/T2020	15 Aug 2007 14:11			
Calibration history of selected sensor				330
S03 TriOxmatic702IQ 01341002				
Date	Relative slope			
03.08.2007	1.13	o.k.	← actual active calibration	
15.08.2007	0.77	Error	← chronological list with the last calibrations	
03.08.2007	1.13	o.k.		
11.07.2007	1.14	o.k.		
20.06.2007	1.05	o.k.		
05.05.2007	1.09	o.k.		
Range of tolerance 0.60 .. 1.20				
Return ESC				

Fig. 4-1 Calibration history TriOxmatic® 702 IQ

The calibration history contains the following information:

- Date of the calibration
- Relative Slope (dimensionless)
- Rating of the calibration:
  - *o.k.*: Calibration was successful.  
The new calibration values are used for the measurements.
  - *Error*: Calibration was not successful.  
The Sensor is blocked for measurement.

### 4.2.4 Reactivation of the last valid calibration (software version 2.21 or higher)

The TriOxmatic® 702 IQ enables you to reactivate the last valid calibration when needed. Thereby, it is possible to continue with measurements, when a calibration failed or it is assumed that optimal calibration conditions were not met.



**Note**

The reactivation of former calibration data is only a temporary solution. Please consider, that thereby possibly wrong measurement values are produced. Please check correct functioning of the sensor by performing a function check and/ or a user calibration.

**Reactivating the last valid calibration data**

1	Open the the setting table (see section 3.4).
2	Choose in the menu item <i>Calibration</i> the setting <i>last valid</i> and quit the setting table afterwards with <i>Save and quit</i> .

### 4.3 Function check

The function check is the simplest way of letting you know whether the sensor needs to be cleaned and calibrated.



#### Note

The function check can either be performed in water vapor-saturated air or in air-saturated water. In the case of air temperatures under 5 °C we recommend to perform the function check not in air but in air-saturated water that has a higher temperature.



#### Note

The function check is carried out in the measuring mode, % saturation. When switching to the measuring mode % saturation, information on linked outputs is lost.

#### Function check in water vapor-saturated air

Proceed as follows:

- |   |  |
|---|--|
| 1 | Take the sensor out of the flow-thru vessel and position it approx. 2 cm above a water surface, best in a narrow bucket or similar container with water. When doing so, no liquid should be brought on the membrane. |
|---|--|

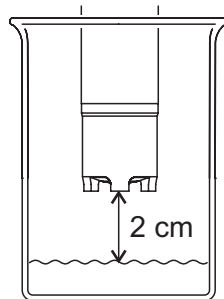

- |   |  |
|---|--|
| 2 | Wait at least 15 minutes for the temperature to adapt.   |
| 3 | In the sensor setting table, select the measuring mode % (unit %) and switch to the measured value display with (M). |
| 4 | Read the measured value and determine whether it lies within the range of precision required by the user.            |



#### Note:

If there are large temperature differences between the sample and the air above the surface of the water, a balancing period of more than 15 minutes may be required.

**Measured values within the required precision**

If the measured value lies within the range of precision required by the user, no cleaning or recalibration is necessary.

Example:

Required precision 5 %.

Measured value in air: 97 % saturation (nominal value: 100%)

⇒ No cleaning or recalibration is necessary as the measurement error lies within the range of precision required by the user.

**Function check in air-saturated water**

In the case of air temperatures under 5 °C do not perform the function check in air but in air-saturated water that has a higher temperature. You obtain air-saturated water by pouring water several times in and out of two vessels so that it sparkles. Then submerge the sensor in a vessel with air-saturated water and perform the function check as described above.

## 5 Maintenance, cleaning, disposal, and replacement

### 5.1 General maintenance instructions



#### Warning

**Contact with the sample can lead to danger to the user! Depending on the type of sample, suitable protective measures must be taken (protective clothing, protective goggles, etc.).**

#### Maintenance condition

We recommend to switch on the maintenance condition each time before removing the sensor from its measuring position. This avoids unintended reactions of linked outputs. For more detailed information on the maintenance condition please refer to the respective IQ SENSOR NET system operating manual.

#### When to unscrew the sensor from the connection cable?

To clean the outside of the sensor (section 5.2) and to replace the electrolyte solution and membrane head (section 5.3), we recommend to leave the sensor connected to the sensor connection cable. Otherwise, moisture and/or dirt can get into the plug connection where they can cause contact problems. If you wish to disconnect the sensor from the sensor connection cable, note the points described below.

For the cleaning of the electrodes (section 5.4) the sensor must be unscrewed from the sensor connection cable to prevent any damage. Observe the following points for this:

- Unscrew the sensor from the SACIQ sensor connection cable.
- Always place a protective cap on the sensor plug head connector and on the SACIQ sensor connection cable so that no moisture or dirt can get into the contacting surfaces.
- In corrosive environments close the dry socket of the sensor connection cable with the SACIQ-Plug protective screw cap in order to protect the electrical contacts from corrosion. The protective cap is available as an accessory (see section 5.8 MAINTENANCE EQUIPMENT AND REPLACEMENT PARTS).
- Connect the sensor with the SACIQ sensor connection cable again before polarization.

### 5.2 Cleaning the sensor shaft and membrane

For normal operation (e.g. boiler feed water), cleaning and calibration are strongly recommended:

- if the measured values are suspected of being incorrect (usually too low)
- if the measured value lies outside the range of precision required by the user during the function check.

#### Cleaning agents

Contamination	Cleaning agents
For loosely adhering dirt or biological deposits	Soft cloth or soft sponge, warm tap water with detergent
Salt and / or lime deposits	Acetic acid (volume percentage = 20 %), soft cloth or soft sponge

#### Cleaning

1	Take the sensor out of the flow-thru vessel and put it into a holding device.
---	---



#### Caution

Acetic acid irritates the eyes and the skin. When handling acetic acid, always wear protective gloves and protective goggles.



#### Caution

Clean the membrane very carefully!  
Make sure that the membrane is not damaged, e.g. by sharp-edged objects.

2	<b>Carefully</b> clean the sensor shaft and the membrane as specified in the CLEANING AGENTS section.
3	Then, rinse it thoroughly with tap water.

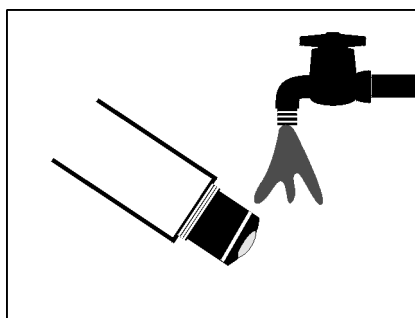



- |   |  |
|---|--|
| 4 | If necessary, carefully dry the membrane with a lint-free paper towel. |
|---|--|

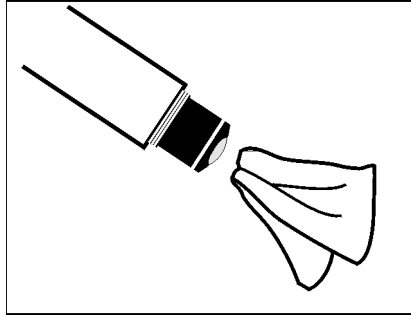

- |   |   |
|---|---|
| 5 | Also clean the flow-thru vessel.                      |
| 6 | Recalibrate the sensor (see section 4.2 CALIBRATION). |
| 7 | Install the sensor again in the flow-thru vessel.     |

### 5.3 Changing the electrolyte and membrane cap

WTW delivers the sensor ready for operation. The electrolyte solution and membrane head must only be replaced:

- the electrolyte solution is depleted or the counter electrode is poisoned (log book message)
- after the gold working electrode and the silver counter electrode have been cleaned



#### Note

Information on the contents and structure of the log book, and how to call it up, is given in the LOG BOOK chapter of the IQ SENSOR NET system operating manual.



#### Note

Only unscrew the membrane head for maintenance purposes. After doing so, always use a new membrane head!

### Changing the electrolyte and membrane cap



- 1 | Take the sensor out of the flow-thru vessel.

#### Caution

The ELY/A electrolyte solution irritates eyes, skin and mucus membranes. If it comes into contact with the eyes, rinse thoroughly with water and consult a doctor! During working activities, always wear suitable protective gloves and protective goggles/face shield! Follow the safety datasheet.

- 2 | Unscrew the membrane head (for disposal of the membrane head and electrolyte solution, see section 5.7).

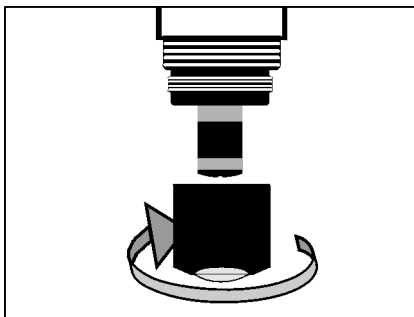

- 3 | Rinse the sensor head with tap water.

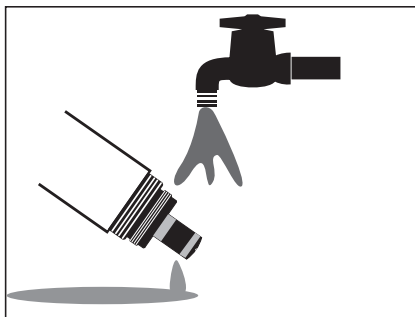

- 4 Carefully rub the silver counter electrode with a paper towel and rinse it with deionized water.

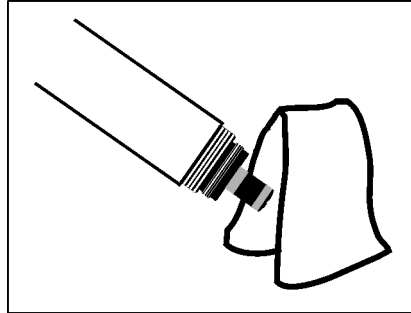

- 5 Thoroughly rinse the sensor head with electrolyte solution.

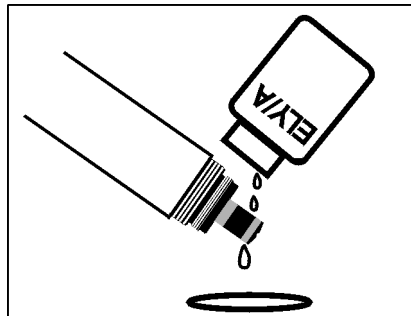

- 6 Fill a new WP 25i membrane cap with ELY/A electrolyte solution (see section 5.8 MAINTENANCE EQUIPMENT AND REPLACEMENT PARTS).

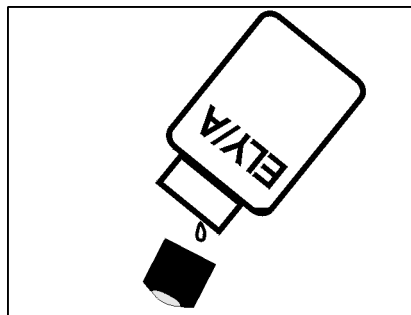

7 | Throw away the first filling and fill the membrane head once more with electrolyte solution.

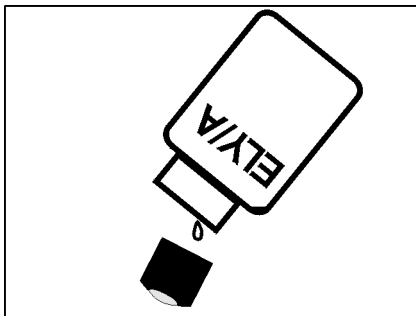

8 | Remove any air bubbles by carefully tapping the membrane head.

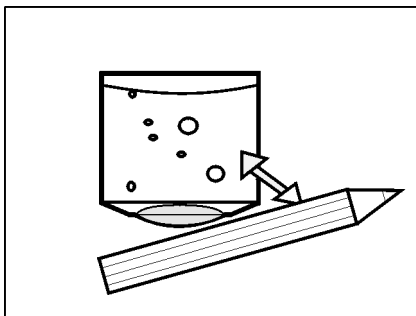

**Caution**

The ELY/A electrolyte solution irritates eyes, skin and mucus membranes. If it comes into contact with the eyes, rinse thoroughly with water and consult a doctor! During working activities, always wear suitable protective gloves and protective goggles/face shield! Follow the safety datasheet.

9 | Screw the membrane head onto the shaft while holding the sensor at an angle. Excess electrolyte solution is forced out of the ventilation area.

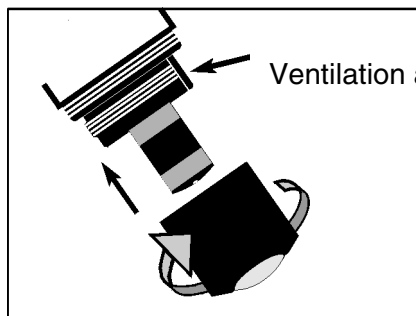



10	The filling should be free of air bubbles as far as possible. However, small air bubbles do not cause any interference.
11	After approx. 60 minutes polarization time, the sensor is ready for operation.
12	Recalibrate the sensor (see section 4.2 CALIBRATION).

### Precision measurements

Recommendation: In order to carry out precision measurements, leave the sensor to polarize for a longer period of time, e.g. overnight, and recalibrate it the following day.



#### Note

In the following cases, you must refill the sensor once more:

- if there are large air bubbles
- if there are air bubbles on the gold working electrode
- for measurements at high water pressure, even if small air bubbles are present. Otherwise, the membrane and, as a result, the measuring characteristics could change.
- if the sensor cannot be calibrated.

## 5.4 Cleaning the electrodes

The counter electrode and reference electrode always exhibit a distinct coloration. This is necessary for the operation of the sensor. This is not contamination. Cleaning is only required in cases of slopes that are too small or too large (the sensor cannot then be calibrated) that cannot be resolved by changing the membrane head and the electrolyte solution.



#### Caution

**To clean the electrodes, always unscrew the sensor from the SACIQ sensor connection cable. Otherwise, undesirable electrochemical reactions can occur that may lead to the destruction of the sensor.**

### Preparatory activities

1	Take the sensor out of the flow-thru vessel.
2	Unscrew the sensor from the SACIQ sensor connection cable (see section 5.1 GENERAL MAINTENANCE INSTRUCTIONS).

**Caution**

The ELY/A electrolyte solution irritates eyes, skin and mucus membranes. If it comes into contact with the eyes, rinse thoroughly with water and consult a doctor! During working activities, always wear suitable protective gloves and protective goggles/face shield! Follow the safety datasheet.

- 3 Unscrew the membrane head (for disposal of the membrane head and electrolyte solution, see section 5.7).

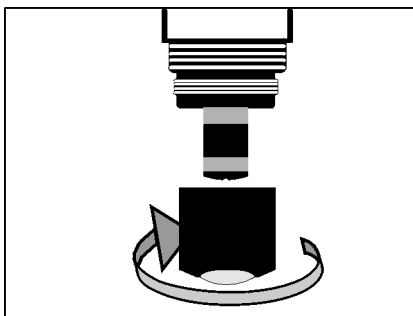

- 4 Rinse the sensor head with tap water.

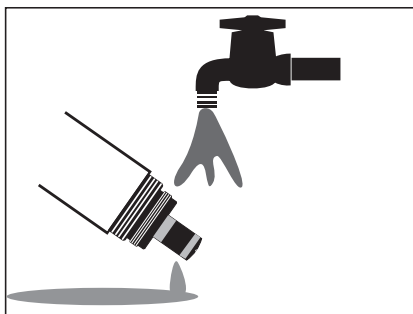

### 5.4.1 Cleaning the gold working electrode

- 1 | Moisten the gold working electrode and the SF 300 polishing strip (see section 5.8 MAINTENANCE EQUIPMENT AND REPLACEMENT PARTS) with deionized water.
- 2 | Using the rough side of the **wet** SF 300 polishing strip, polish off any contamination from the gold working electrode using light pressure.

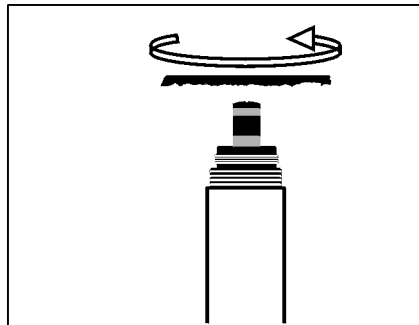

#### Caution

Do not use any conventional sandpaper or glass-fiber brushes. They could damage the electrode.

- 3 | Rinse the sensor head with deionized water.

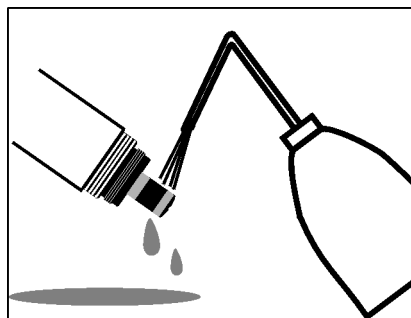

#### Note

Cleaning the gold working electrode may already be sufficient to enable the sensor to be calibrated again. For safety, however, we recommend to also clean the silver counter electrode (see section 5.4.2) and to use a new membrane cap afterwards.

### 5.4.2 Cleaning the silver counter electrode



#### Caution

The reference electrode must not come into contact with the cleaning solution under any circumstances. This could destroy the reference electrode and cause the sensor to become defective. However, no danger can arise if the RA 600 cleaning attachment is used correctly.

**Cleaning the silver counter electrode with the RA 600 cleaning attachment**

- 1 Wipe the silver counter electrode with a lint-free paper towel and carefully remove any loose deposits.

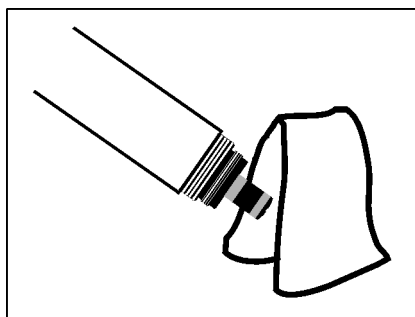

- 2 Screw the cleaning attachment onto the sensor, instead of the membrane head.

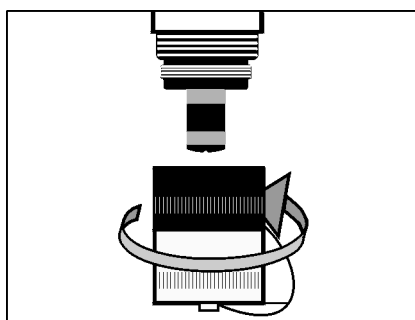

#### Caution

Never grease or lubricate the inner O-ring in the RA 600 cleaning attachment!



- 3 Remove the screw cap from the safety cap of the cleaning attachment.

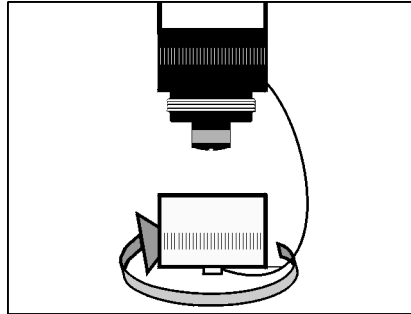

- 4 Fill the screw cap with RL-AG/Oxi cleaning solution (see section 5.8 MAINTENANCE EQUIPMENT AND REPLACEMENT PARTS).

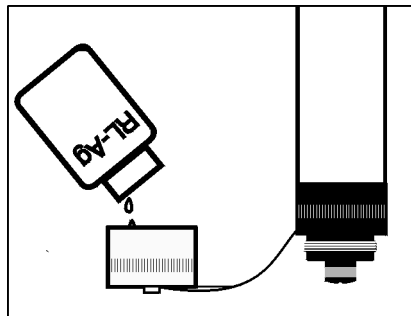

- 5 Screw the sensor with the safety cap onto the screw cap.

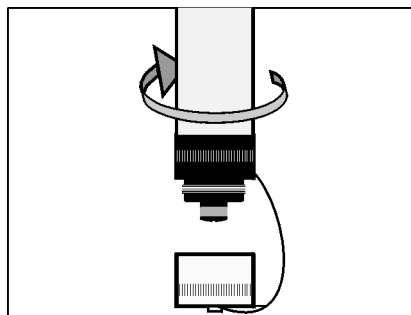

- 6 Leave the cleaning solution to take effect for a maximum of 1 hour.

7 | Unscrew the screw cap.

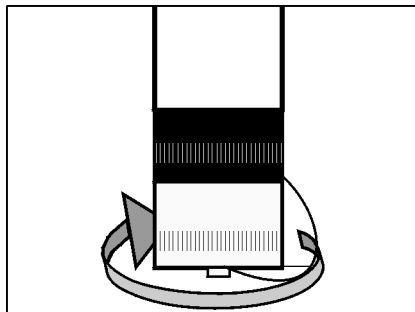

8 | Thoroughly rinse the electrode unit with the safety cap on with deionized water.

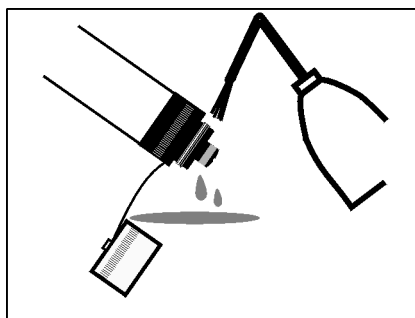

9 | Unscrew the safety cap.

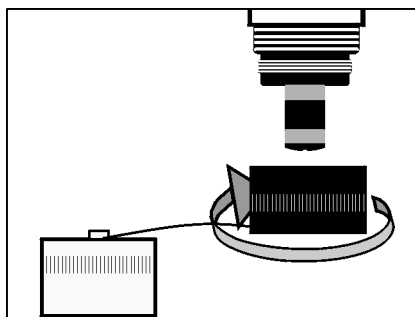

- 10 Rinse the sensor head and the electrode unit several times with deionized water.

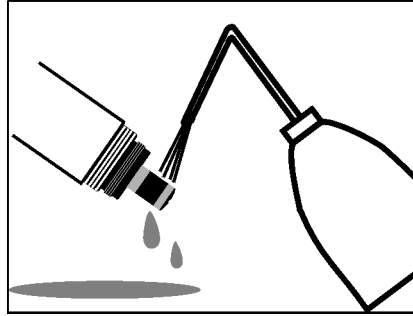

- 11 Rinse the sensor head and the electrode unit for at least an hour in deionized water.

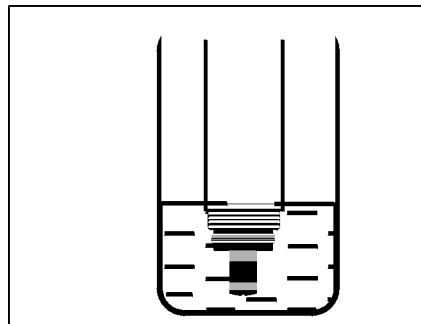

- 12 Carefully shake off the drops of water.

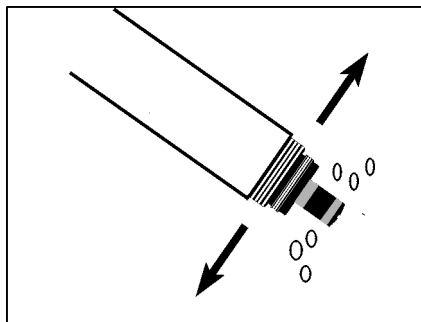

- 13 Fill a new WP 25i membrane cap and screw it on (see section 5.3 CHANGING THE ELECTROLYTE AND MEMBRANE CAP).
- 14 Connect the sensor again with the SACIQ sensor connection cable.
- 15 After approx. 60 minutes, the sensor is ready for operation.
- 16 Recalibrate the sensor (see section 4.2 CALIBRATION).



## 5.5 Check the sensor for freedom from zero current

The sensor is zero-current free. Therefore, no calibration of the sensor in an oxygen-free solution is included.

However, it is possible to check the freedom from zero-current according to DIN EN 25814/ISO 5814. This is advisable if there is any suspicion of a malfunction.

### Test solution

1 g/l aqueous sodium sulfite solution,  $\text{Na}_2\text{SO}_3$   
(addition of 1 mg/l of a cobalt(II) salt accelerates the removal of oxygen from the solution.)



The sensor should be in operation for at least 1 hour before the inspection.

### Test procedure



1	Clean the sensor (see section 5.2 CLEANING THE SENSOR SHAFT AND MEMBRANE).
2	In the sensor setting table, select the measuring mode % (unit %) and switch to the measured value display with (M).
3	Submerge the sensor in the test solution.
4	Leave the sensor in the test solution for an hour.
5	Read the measured value.

### Evaluation

The sensor is OK if the terminal shows < 1 % oxygen saturation.

If the measured value is > 1 %:

- Clean the gold working electrode (see section 5.4.1 CLEANING THE GOLD WORKING ELECTRODE) and change the electrolyte and membrane cap (see section 5.3 CHANGING THE ELECTROLYTE AND MEMBRANE CAP).
- If necessary, also clean the silver counter electrode (see section 5.4.2 CLEANING THE SILVER COUNTER ELECTRODE).

## 5.6 Storage

Store the clean and dry sensor with its protective cap in place. Observe the allowed temperature range (see chapter 7 TECHNICAL DATA); the sensor may be stored in any position.

## 5.7 Disposal

We recommend disposing of the sensor without the membrane head as electronic refuse.



### Caution

**The ELY/A electrolyte solution irritates eyes, skin and mucus membranes. If it comes into contact with the eyes, rinse thoroughly with water and consult a doctor! During working activities, always wear suitable protective gloves and protective goggles/face shield! Follow the safety datasheet.**

### Disposal of the membrane cap

1	Before disposing of the membrane head, unscrew it and rinse with water.
2	Dispose of the membrane head in the household refuse.



### Note

To dispose of the chemicals, follow the corresponding safety datasheets. The safety datasheets can be obtained from WTW.

## 5.8 Maintenance equipment and replacement parts

Description	Model	Order no.
Accessory case (2 replacement membrane heads, 50 ml electrolyte solution, 50 ml cleaning solution, polishing film)	ZBK 25i	202 621
Replacement membrane heads (2 pieces)	WP 25i/2	202 852
Electrolyte solution (1 bottle x 50 ml)	ELY/A	205 212
Cleaning solution for silver counter electrode (1 bottle of 50 ml)	RL-Ag/Oxi	205 200
Polishing film	SF 300	203 680
Cleaning attachment for cleaning the counter electrode	RA 600	202 510
Protective screw cap for sensor connection cable	SACIQ-Plug	480 065



### Note

Information on other IQ SENSOR NET accessories is given in the WTW catalog and on the Internet.





## 6 What to do if...

**The sensor is in the air and the display shows 0.0 mg/l or 0 % O<sub>2</sub>**

Cause	Remedy
<ul style="list-style-type: none"> <li>– No electrolyte in the membrane head</li> </ul>	<ul style="list-style-type: none"> <li>– Change the WP 25i membrane head (see section 5.3)</li> </ul>

**The sensor cannot be calibrated**

Cause	Remedy
<ul style="list-style-type: none"> <li>– Contaminated membrane head</li> </ul>	<ul style="list-style-type: none"> <li>– Clean the outside of the sensor (according to operating manual), wait at least 15 minutes and recalibrate it.</li> <li>– In the case of contamination that cannot be removed: Change the membrane head and electrolyte</li> </ul>

**If the sensor still cannot be calibrated after changing the electrolyte and membrane cap**

Cause	Remedy
<ul style="list-style-type: none"> <li>– Contaminated electrodes or sensor toxification</li> </ul>	<ul style="list-style-type: none"> <li>– Clean the electrodes (see section 5.4)</li> </ul>

**Mechanical damage to the sensor**

Cause	Remedy
	<ul style="list-style-type: none"> <li>– Return the sensor</li> </ul>

**Measured values too low**

Cause	Remedy
<ul style="list-style-type: none"> <li>– Membrane contaminated</li> <li>– Sensor has not been calibrated for a long time</li> </ul>	<ul style="list-style-type: none"> <li>– Clean the outside of the sensor, then recalibrate (see section 5.2 and section 4.2)</li> </ul>
<ul style="list-style-type: none"> <li>– Membrane does not fit snugly on the gold working electrode</li> </ul>	<ul style="list-style-type: none"> <li>– Change the membrane cap, then recalibrate (see section 5.3 and section 4.2)</li> </ul>
<ul style="list-style-type: none"> <li>– Minimum approach flow not present</li> </ul>	<ul style="list-style-type: none"> <li>– Ensure sufficient approach flow</li> </ul>

<b>Measured value fluctuating heavily</b>	<b>Cause</b>	<b>Remedy</b>
	<ul style="list-style-type: none"><li>– Membrane cap loose</li></ul>	<ul style="list-style-type: none"><li>– Screw the membrane head tight</li></ul>
<b>Measured values too high</b>	<b>Cause</b>	<b>Remedy</b>
	<ul style="list-style-type: none"><li>– Membrane does not fit snugly on the gold working electrode</li></ul>	<ul style="list-style-type: none"><li>– Change the membrane cap, then recalibrate (see section 5.3 and section 4.2)</li></ul>
<b>Incorrect temperature display</b>	<b>Cause</b>	<b>Remedy</b>
	<ul style="list-style-type: none"><li>– Sensor not yet completely polarized</li><li>– Sensor has not been calibrated for a long time</li></ul>	<ul style="list-style-type: none"><li>– Wait for complete polarization (at least 1 hour)</li><li>– Clean the outside of the sensor, then recalibrate (see section 5.2 and section 4.2)</li></ul>
<b>Incorrect temperature display</b>	<b>Cause</b>	<b>Remedy</b>
	<ul style="list-style-type: none"><li>– Temperature sensor defective</li></ul>	<ul style="list-style-type: none"><li>– Return the sensor</li></ul>

## 7 Technical data

### 7.1 Measurement characteristics

<b>Measuring principle</b>	Membrane-covered amperometric sensor with potentiostatically operated 3-electrode system; Integrated microprocessor electronics, shielded 2-wire connection for power and data transmission.		
<b>Electrolyte</b>	ELY/A		
<b>Measuring ranges and resolutions</b>	<b>Measuring mode</b>	<b>Measuring range</b>	<b>Resolution</b>
	D. O. concentration	0 ... 2000 µg/l 0.00 ... 10.00 mg/l	1 µg/l 0.01 mg/l
	D. O. saturation	0.0 ... 110.0 %	0.1 %
<b>Temperature compensation</b>	IMT (integrated membrane temperature compensation)		
<b>Measurement in water</b>	According to solubility function DIN 408 / Part 22		
<b>Measurement in salt-contaminated wastewater</b>	Salinity input from 2.0 ... 70.0; corresponds to 3.4 mS/cm ... 86.2 mS/cm at T <sub>REF</sub> 20 °C (salinity measurement in the range 2 ... 42 according to IOT = International Oceanographic Tables)		
<b>Polarization time</b>	In the case of recommissioning or change of electrolyte	At least 60 minutes	
	for precision measurements	At least 120 minutes and recalibrate on the following day	
	In the case of short polarization interruptions (depending on the duration of the interruption)	30 to 120 minutes	
<b>Temperature measurement</b>	Temperature sensor	integrated NTC	
	Measuring range	- 5 °C ... + 60 °C (23 ... 140 °F)	
	Accuracy	± 0.5 K	
	Resolution	0.1 K	
<b>Calibration procedure</b>	Air calibration		

<b>Air pressure compensation</b>	Automatic	With IQ SENSOR NET systems with air pressure measurement (option)
	Manual	By entering the air pressure or location altitude

## 7.2 Application characteristics

<b>Allowed temperature range</b>	Measuring medium	0 °C ... + 60 °C (32 ... 140 °F)
	Storage/transport	- 5 °C ... + 65 °C (23 ... 149 °F)
<b>Allowed pH range of the test sample</b>	4 ... 12	
<b>Pressure resistance</b>	Sensor with connected SACIQ sensor connection cable:	
	Max. allowed overpressure	10 <sup>6</sup> Pa (10 bar)
The sensor meets all requirements according to article 3(3) of 97/23/EC ("pressure equipment directive").		
<b>Type of protection</b>	Sensor with connected SACIQ sensor connection cable: IP 68, 10 bar (10 <sup>6</sup> Pa)	
<b>Immersion depth</b>	min. 10 cm; max. 100 m depth	
<b>Operating position</b>	Predominantly for installation in the D 702/N flow-thru vessel	
<b>Approach flow</b>	≥ 0.3 m/s (at 1 % measuring accuracy)	
<b>Flow-thru in the D 702/N</b>	≥ 100 ml/min	
<b>Field of application</b>	Oxygen trace sensor, for monitoring boiler feed water for example	

### 7.3 General data

#### Dimensions

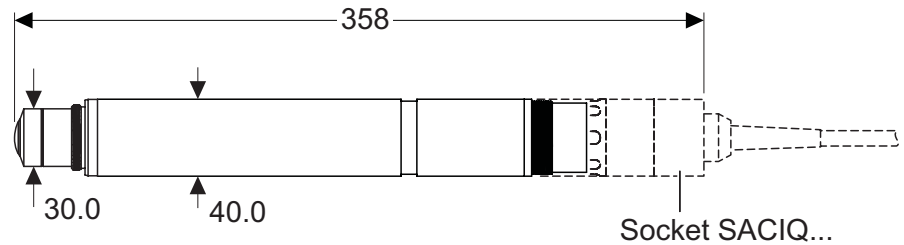

#### Weight (without sensor connection cable)

approx. 660 g

#### Connection technique

Connection via SACIQ sensor connection cable

#### Material

Shaft	V4A stainless steel 1.4571
Membrane head	POM
Membrane	FEP (thickness 25 µm)
Sensor head	POM
Insulator	PEEK
Plug head connector housing	POM
Plug, 3-pole	ETFE (blue) Tefzel®

#### Automatic sensor monitoring (SensCheck function)

- SensReg (electrolyte solution depleted)

#### Instrument safety

Applicable norms	<ul style="list-style-type: none"> <li>– EN 61010-1</li> <li>– UL 3111-1</li> <li>– CAN/CSA C22.2 No. 1010.1</li> </ul>
------------------	---

### 7.4 Electrical data

Nominal voltage	Max. 24VDC via the IQ SENSOR NET (for more details, see chapter TECHNICAL DATA of the IQ SENSOR NET system operating manual)
Power consumption	0.2 W
Protective class	III

### 7.5 Characteristic data on delivery

**Zero signal** < 1 ppb (0.001 mg/l)

**Response time at 25 °C**  
 $t_{90}$  (90 % of the final value display after) < 30 s  
 $t_{99}$  (99 % of the final value display after) < 110 s

**Adjustment time** Adjustment time for measuring low oxygen concentrations after air calibration:

D. O. concentration	Adjustment time
10 ppb	10 min
5 ppb	15 min
< 2 ppb	45 min

Adjustment time for measuring low oxygen concentrations after exchanging the membrane head and electrolyte solution and subsequent air calibration:

D. O. concentration	Adjustment time
10 ppb	40 min
5 ppb	70 min
< 2 ppb	180 min

**Own consumption** 0.34  $\mu\text{g h}^{-1} (\text{mg/l})^{-1}$  at 20 °C

**Drift** < 1 % per month during permanent polarization

**Working life per electrolyte filling**

D. O. concentration	Theoretical electrolyte reserve
Air saturation	approx. 45 days
< 100 ppb	approx. 12 years

## 8 Indexes

### 8.1 Explanation of the messages

This chapter contains a list of all the message codes and related message texts that can occur in the log book of the IQ SENSOR NET system for the TriOxmatic® 702 IQ sensor.



#### Note

Information on the contents and structure of the log book, and how to call it up, is given in the LOG BOOK chapter of the IQ SENSOR NET system operating manual.



#### Note

All message codes of the TriOxmatic® 702 IQ end up with "333".

#### 8.1.1 Error messages

#### Message code

#### Message text

EA1333

*Meas. range exceeded or undercut*  
 \* Check process  
 \* Select other meas. range

EA2333

*Sensor temperature too high!*  
 \* Check process and application

EA3333

*Sensor temperature too low!*  
 \* Check process and application

EC4333

*Sensor could not be calibrated,  
 sensor blocked for measurement*  
*Cause: instable signal*  
 \* Check polarization time and temperature adjustment  
 \* Check calibration conditions  
 \* Read calibration history  
 \* Repeat calibration, if unsuccessful: service the sensor (see operating manual)

EC5333

*Sensor could not be calibrated,  
 sensor blocked for measurement*  
*Cause: slope error*  
 \* Check polarization time and temperature adjustment  
 \* Check calibration conditions  
 \* Read calibration history  
 \* Repeat calibration, if unsuccessful: service the sensor (see operating manual)

---

<b>Message code</b>	<b>Message text</b>
EI1333	<i>Operational voltage too low</i> <i>* Check installation and cable lengths, Follow installation instructions</i> <i>* Power unit(s) overloaded, add power unit(s)</i> <i>* Check terminal and module connections</i> <i>* Defective components, replace components</i>
EI2333	<i>Operational voltage too low, no operation possible</i> <i>* Check installation and cable lengths, Follow installation instructions</i> <i>* Power unit(s) overloaded, add power unit(s)</i> <i>* Check terminal and module connections</i> <i>* Defective components, replace components</i>
ES1333	<i>Component hardware defective</i> <i>* Contact WTW</i>
ESB333	<i>SensReg: Electrolyte supply is depleted</i> <i>* Change electrolyte solution and membrane head immediately (see operating manual)</i>

### **8.1.2 Info messages**

<b>Message code</b>	<b>Message text</b>
IC1333	<i>Sensor has been successfully calibrated</i> <i>* For calibration data, see calibration history</i>
IC4333	<i>Last valid calibration has been activated. Make sure the sensor operates correctly.</i>
II1333	<i>Language not available,</i> <i>Default language German</i> <i>* Contact WTW</i>



## 8.2 Status info

The status info is a coded piece of information on the current status of a sensor. Each sensor sends this status info to the controller. The status info of sensors consists of 32 bits, each of which can have the value 0 or 1.

### Status info, general structure

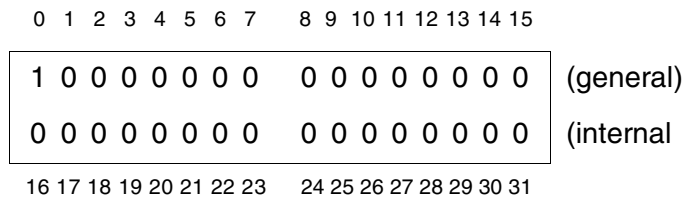

The bits 0 - 15 are reserved for general information.  
The bits 16 - 21 are reserved for internal service information.

You obtain the status info:

- via a manual query in the *Einstellungen/Service/List of all components* menu (see system operating manual)
- by an automated query
  - of a superordinate process control (e. g. when connected to the Profibus)
  - from the IQ Data Server (see IQ SENSOR NET Software Pack operating manual)



### Note

The evaluation of the status info, e.g. in the case of an automated query, has to be made individually for each bit.

### Status info TriOxmatic® 702 IQ

Status bit	Explanation
Bit 0	<i>Component hardware defective</i>
Bit 1	<i>SensReg: Electrolyte supply is depleted</i>
Bit 2-31	-





# Xylem | 'zīləm|

- 1) The tissue in plants that brings water upward from the roots;
- 2) a leading global water technology company.

We're a global team unified in a common purpose: creating advanced technology solutions to the world's water challenges. Developing new technologies that will improve the way water is used, conserved, and re-used in the future is central to our work. Our products and services move, treat, analyze, monitor and return water to the environment, in public utility, industrial, residential and commercial building services settings. Xylem also provides a leading portfolio of smart metering, network technologies and advanced analytics solutions for water, electric and gas utilities. In more than 150 countries, we have strong, long-standing relationships with customers who know us for our powerful combination of leading product brands and applications expertise with a strong focus on developing comprehensive, sustainable solutions.

**For more information on how Xylem can help you, go to [www.xylem.com](http://www.xylem.com).**



## **Service and Returns:**

Xylem Analytics Germany  
Sales GmbH & Co. KG  
WTW  
Am Achalaich 11  
82362 Weilheim  
Germany

Tel.: +49 881 183-325

Fax: +49 881 183-414

E-Mail [wtw.rma@xylem.com](mailto:wtw.rma@xylem.com)

Internet: [www.xylemanalytics.com](http://www.xylemanalytics.com)



Xylem Analytics Germany GmbH  
Am Achalaich 11  
82362 Weilheim  
Germany

